

IP175C CHIP

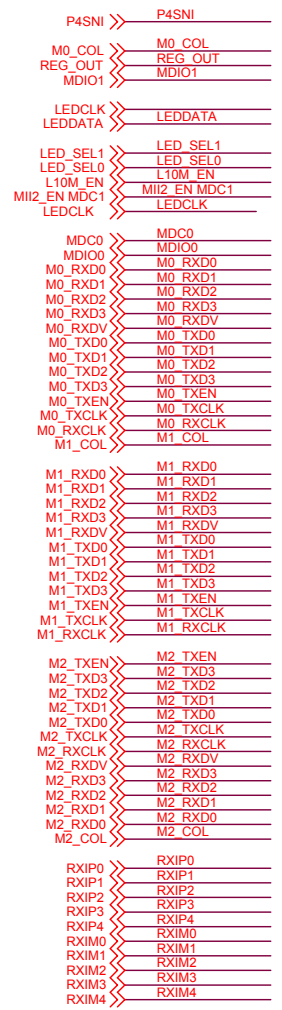

Signal Connect



Title		IP175C_Three_MII	
Size	Document Number	IP175C CHIP	
B			Rev
			V8.0
Date:	Sunday, July 10, 2011	Sheet	2 of 6

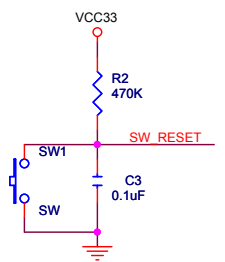

RESET

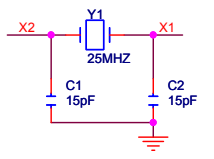

CLOCK

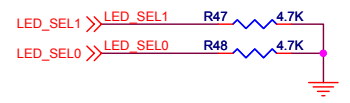

LED MODE SELECT

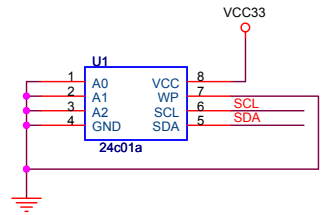

EEPROM

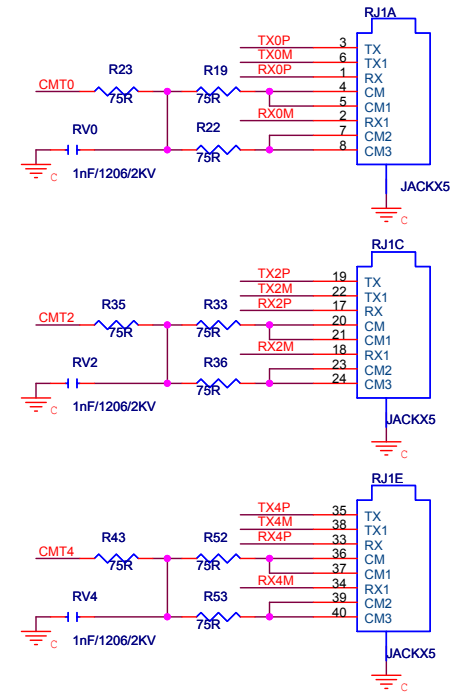
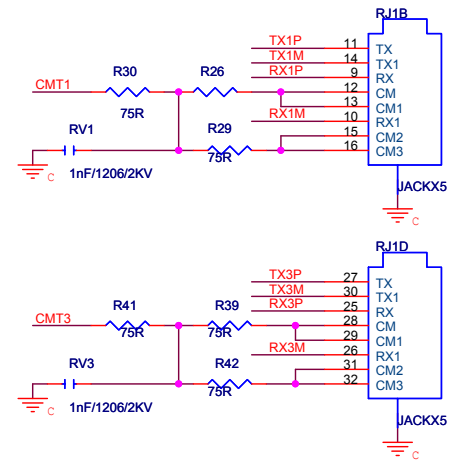
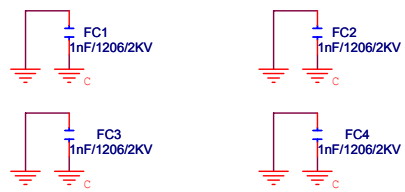
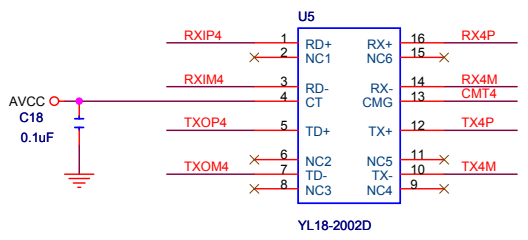
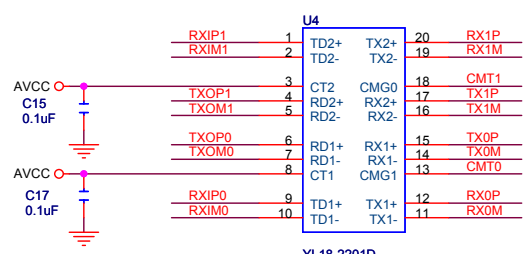
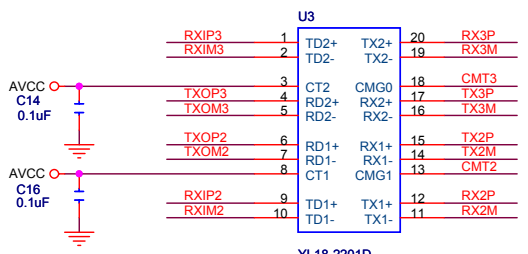
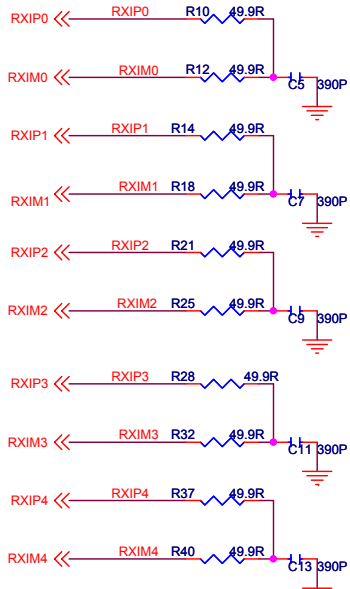
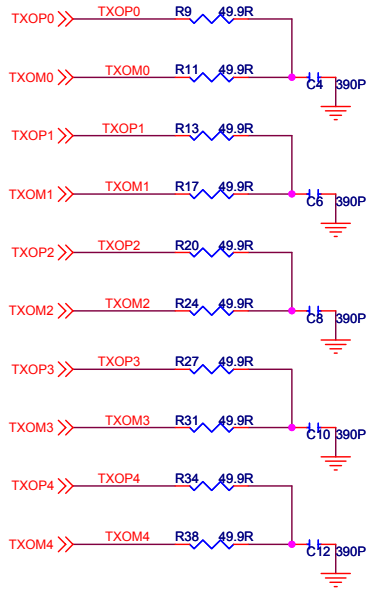

Reference Transformer Part No. list  
 YL18-2002D, YL18-2201D  
 YuTai Electronics Co.,LTD  
 TEL:86-574-63620701,63621610  
 http://www.yutai-elec.com  
 EMAIL: nico\_yu@yeah.net

# MDIX

## TRANSFORMER&RJ45 CIRCUITS

<b>IC+</b>		
Title		
<b>IP175C_Three_MII</b>		
Size B	Document Number	Rev
	<b>TRANSFORMER&amp;RJ45</b>	V8.0
Date:	Sunday, July 10, 2011	Sheet 3 of 6

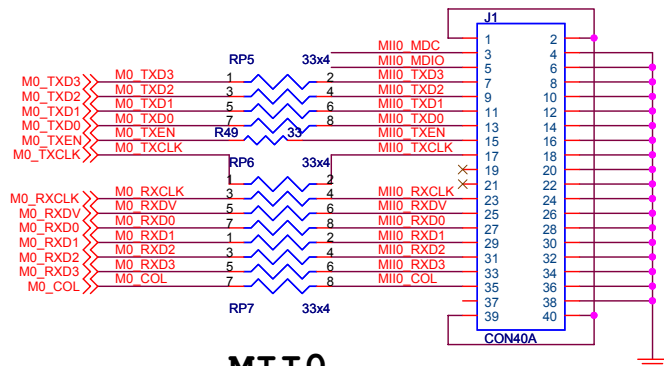

### MIIO

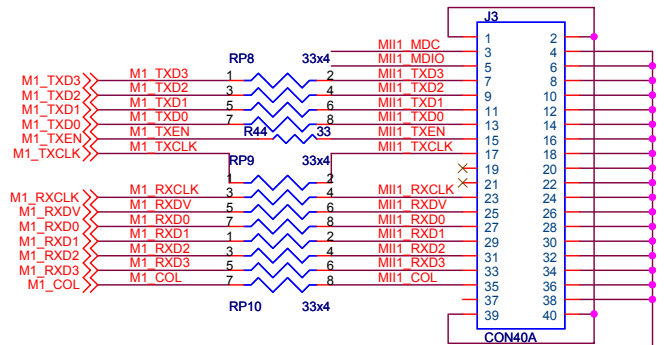

### MII1

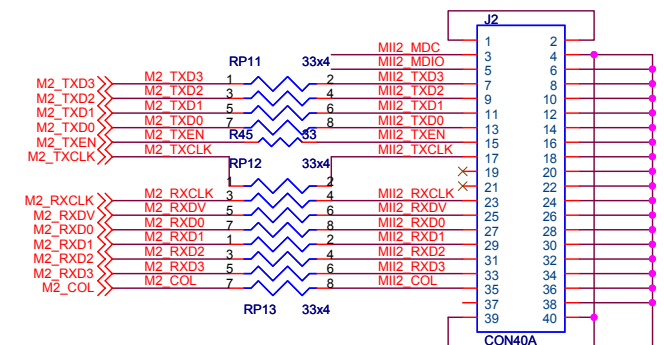

### MII2

## Three MII Connection

### Three MII Setting

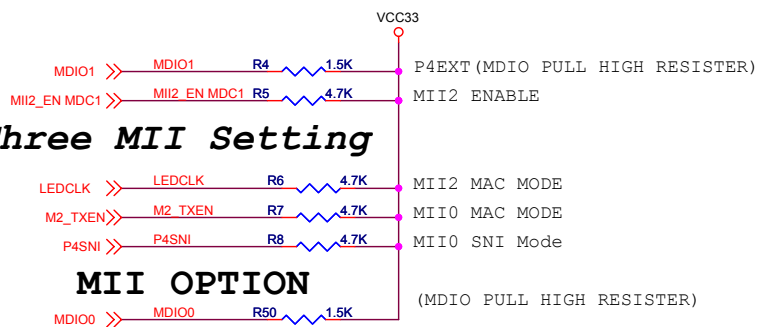

### MII OPTION

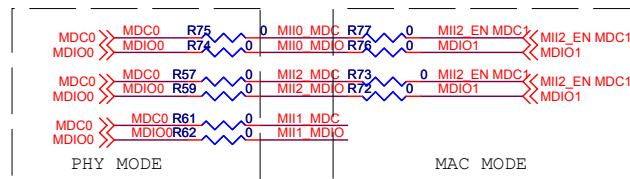

*MDC1/MDIO1 is used by IP175C to access an External PHY. MDC0/MDIO0 is used by External MAC to access IP175C.*

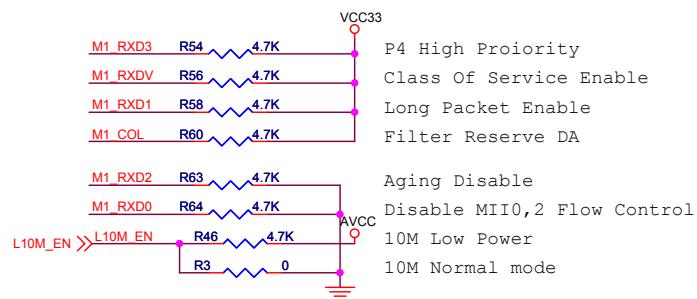

*When MII2 is enabled, PxFORce, PxFORce 100, PxFORce full, MII0\_MAC Mode, X\_en, Broadcast storm control can be configed by MII register only.*

### Option Setting

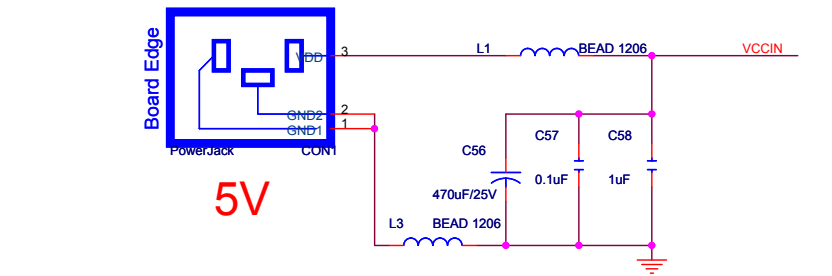

5V

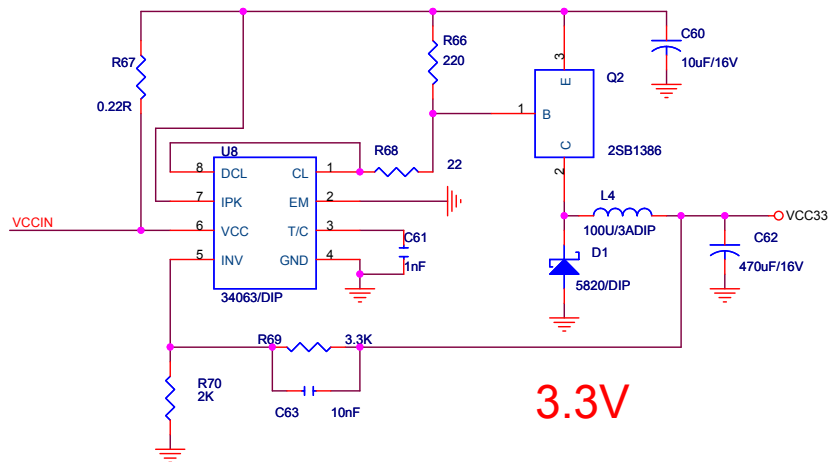

3.3V

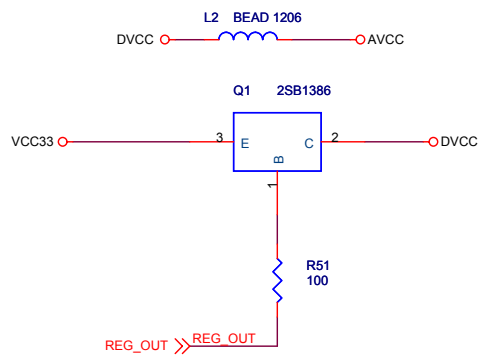

POWER CIRCUITS

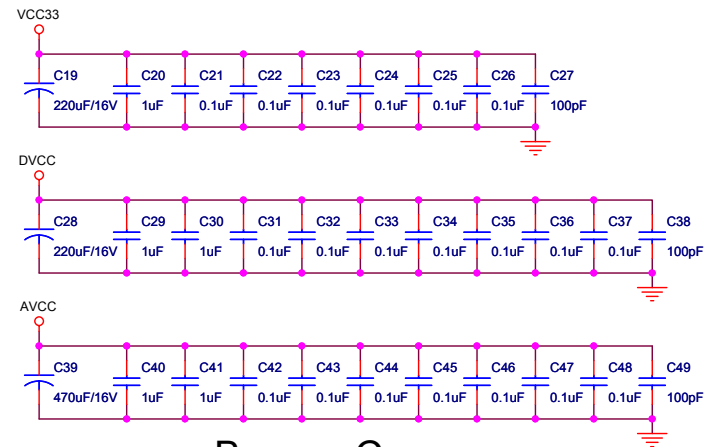

Bypass Cap.

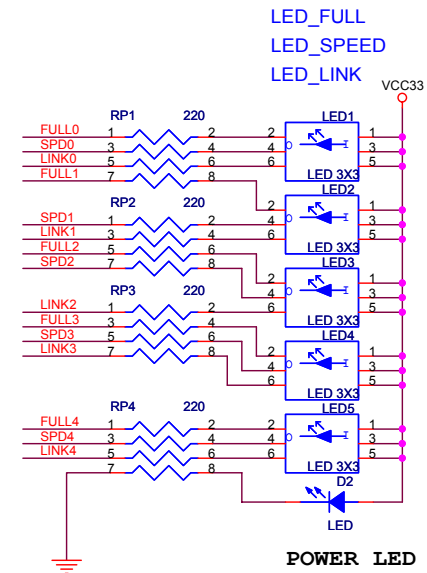
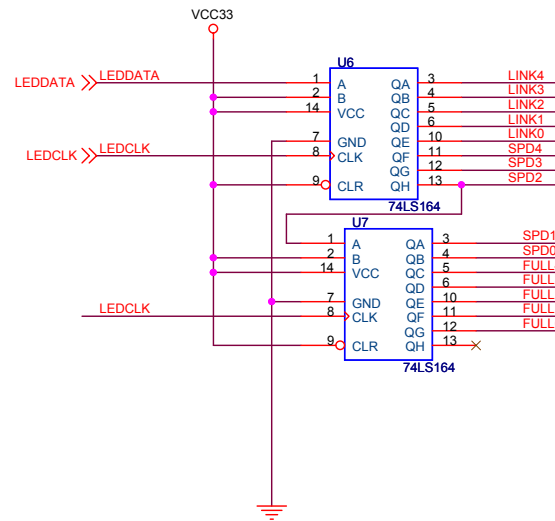

LED CIRCUITS

<b>IC+</b>		
Title		
<b>IP175C_Three_MII</b>		
Size	Document Number	Rev
B	<b>Power</b>	V8.0
Date:	Sunday, July 10, 2011	Sheet 5 of 6

**IP175C\_R08.DSN compares with IP175C\_R07.DSN**

VERSION	IP175C_R07.DSN					IP175C_R08.DSN				
	PIN NO.	PIN NAME	PARTS	APPLICATION CIRCUIT	SYMBOL	PIN NO.	PIN NAME	PARTS	APPLICATION CIRCUIT	SYMBOL
PAGE3				RV0,RV1, RV2,RV3, RV4 :.1U/1206/2KV					RV0,RV1, RV2,RV3, RV4 :1nF/1206/2KV	
PAGE3				FC1,FC2, FC3,FC4 :.01U/1206/2KV					FC1,FC2, FC3,FC4 :1nF/1206/2KV	

		
Title		
<b>IP175C_Three_MII</b>		
Size	Document Number	Rev
B		V8.0
Date: Sunday, July 10, 2011		Sheet 6 of 6
		<b>Note</b>