

# RTL8211D-VB/8211E-VB/8211E-VL Schematic

**REV.1.6**

<b>Page</b>	<b>Index</b>
<b>1.</b>	<b>Title Page</b>
<b>2.</b>	<b>PHY</b>
<b>3.</b>	<b>MDI</b>
<b>4.</b>	<b>CMC</b>
<b>5.</b>	<b>Power</b>
<b>6.</b>	<b>History</b>

<b>Title</b>			
<b>RTL8211D/8211E</b>			
<b>Size</b>	<b>Document Number</b>	<b>TITLE PAGE</b>	<b>Rev</b>
A3			
<b>Date:</b>	<b>Sheet</b>	<b>1</b>	<b>of 6</b>

## External clock and Crystal

External clock source from OSC or Chipset.

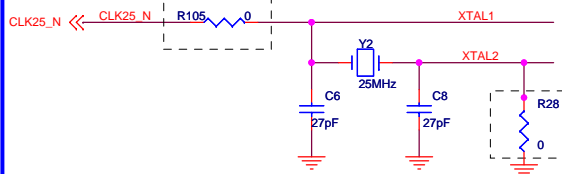

If use external clock then the XTAL2 need connect to GND for RTL8211E.  
R28 NC for RTL8211D

## Enable/Disable SWREG

### AVDD33

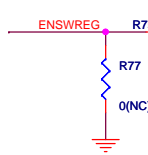

Connect ENSWREG to AVDD33 to enable Switching regulator or connect ENSWREG to GND to disable Switching regulator.

Enable SWREG: R75  
Disable SWREG: R77

## PHY Reset

### DVDD33

For wake on LAN function, please keep PHYRSTB pin to high.

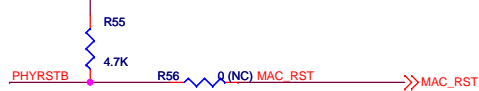

## WOL & Interrupt

### DVDD33



## RTL8211D/8211E

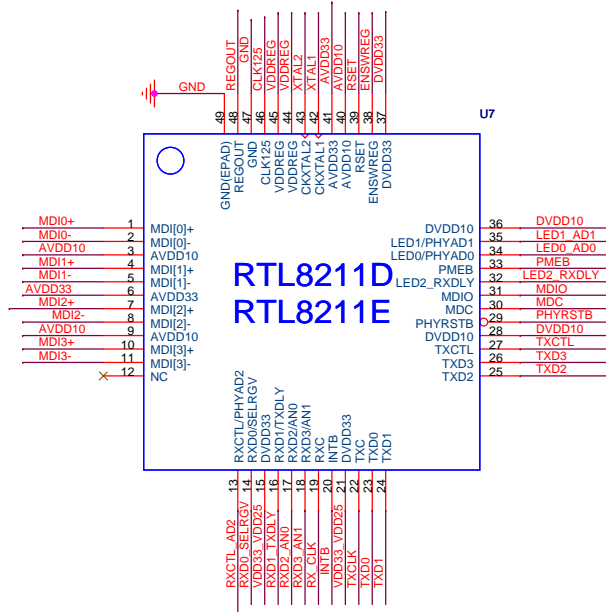

## RGMII Interface

Place filter network close to RX\_CLK.  
Reserved for EMI

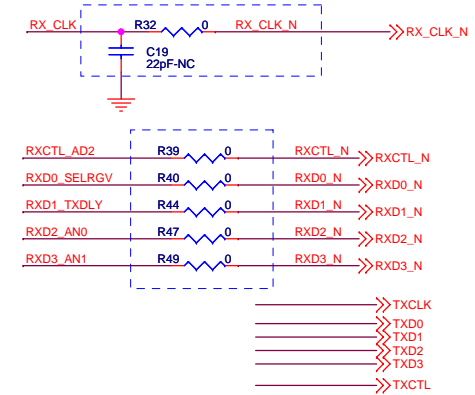

## Power

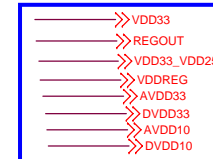

## RSET

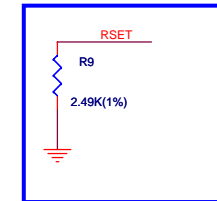

## Configuration Setting

### DVDD33

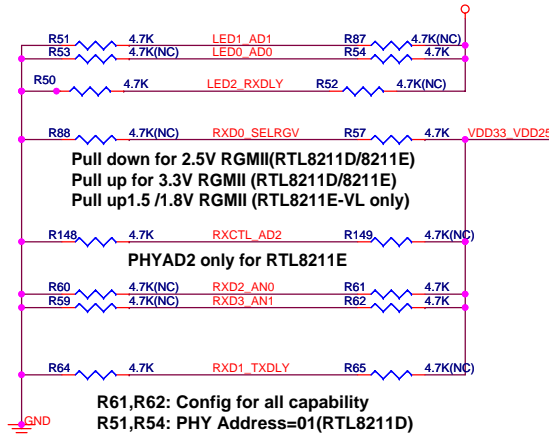

Pull down for 2.5V RGMII(RTL8211D/8211E)  
Pull up for 3.3V RGMII (RTL8211D/8211E)  
Pull up 1.5 / 1.8V RGMII (RTL8211E-VL only)

PHYAD2 only for RTL8211E

R61,R62: Config for all capability  
R51,R54: PHY Address=01(RTL8211D)  
R51,R54,R148: PHY Address=001(RTL8211E)  
R64,R50: Without TX/RX Delay

## Output Clock

Place filter network close to CLK125.  
Reserved for EMI

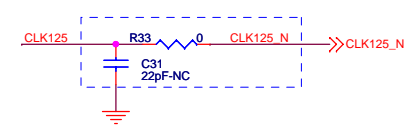

## MDC/MDIO

### DVDD33

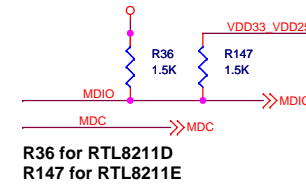

R36 for RTL8211D  
R147 for RTL8211E

Title		RTL8211D/8211E	
Size	A3	Document Number	PHY
Date:		Rev	
Sheet		2 of 6	

## RJ45 & Transformer

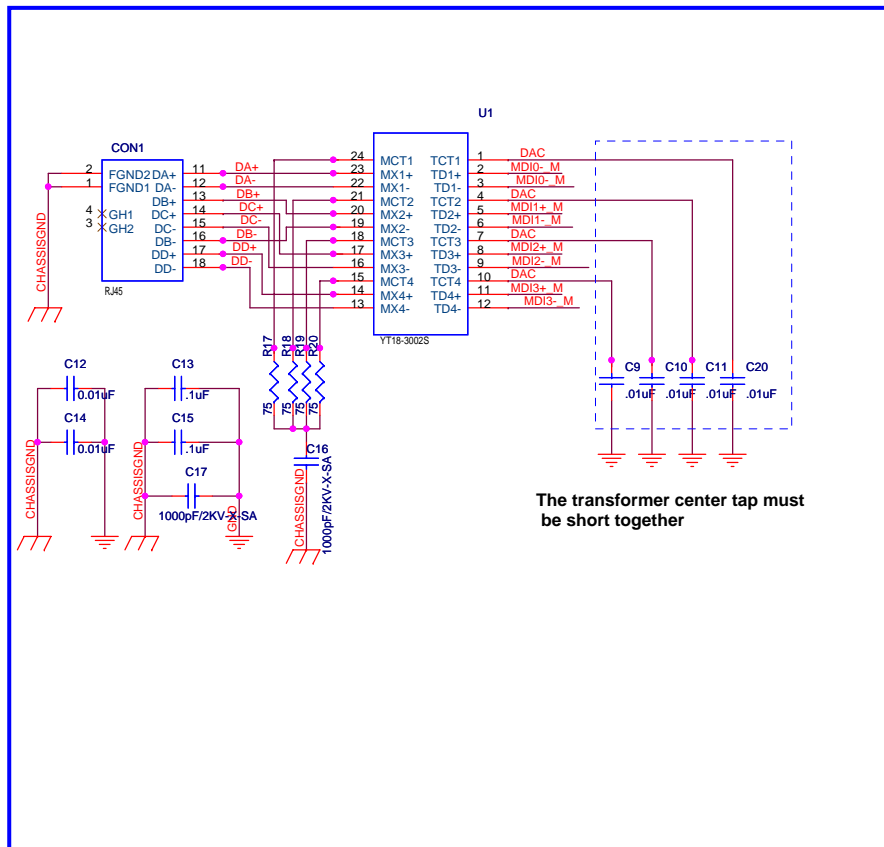

## LED

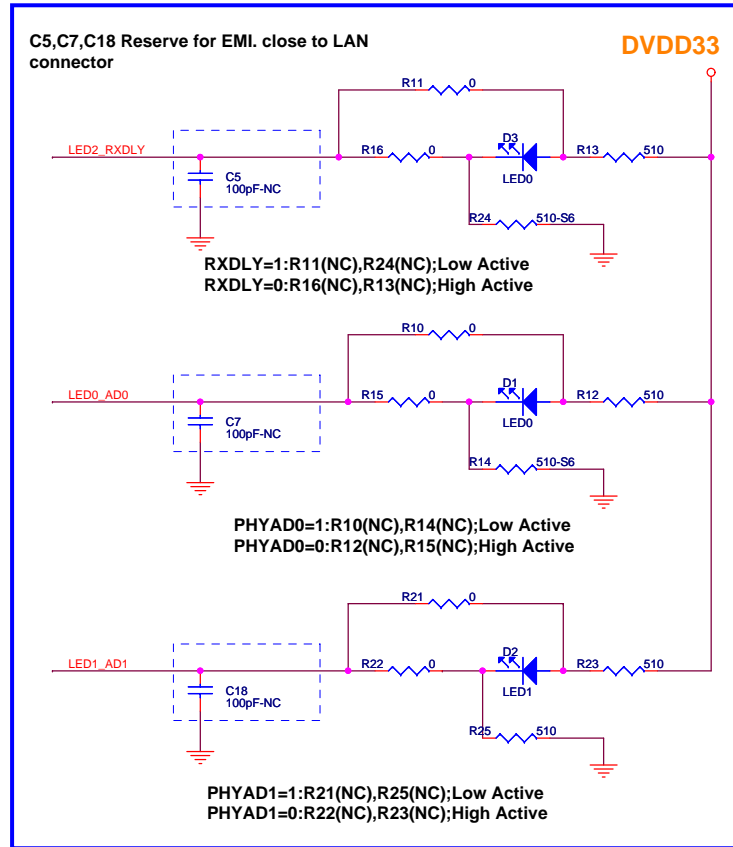

## TVS

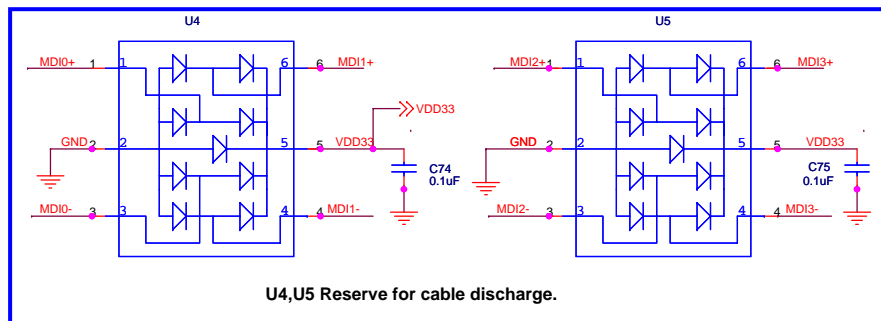

Title **RTL8211D/8211E**

Size A3 Document Number

**MDI**

Date:

Sheet 3 of 6

Rev

# Common mode choke (Option)

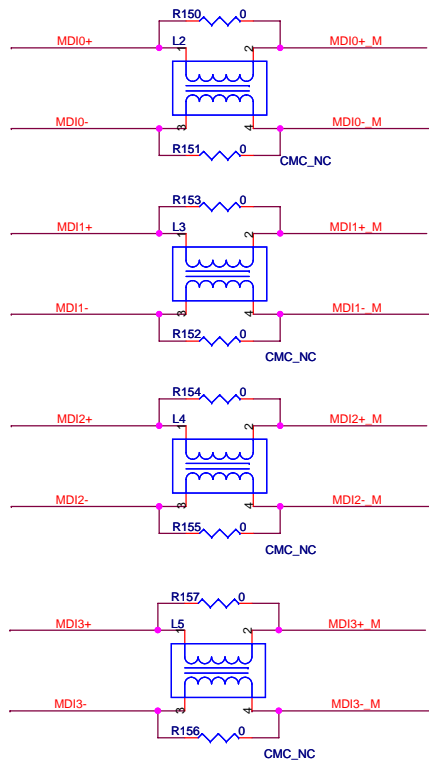

L2,L3,L4,L5 Reserve for EMI, close to transformer.

Title		RTL8211D/8211E	
Size	Document Number	Rev	
A3	CMC		
Date:	Sheet	4	of 6

### 3.3V Power

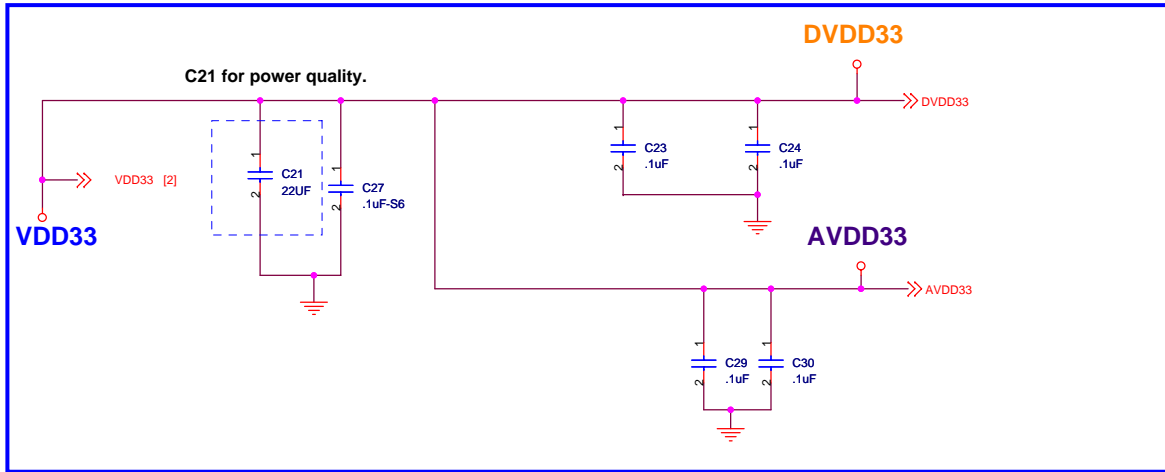

### 3.3/2.5V/1.8/1.5V RGMII Power

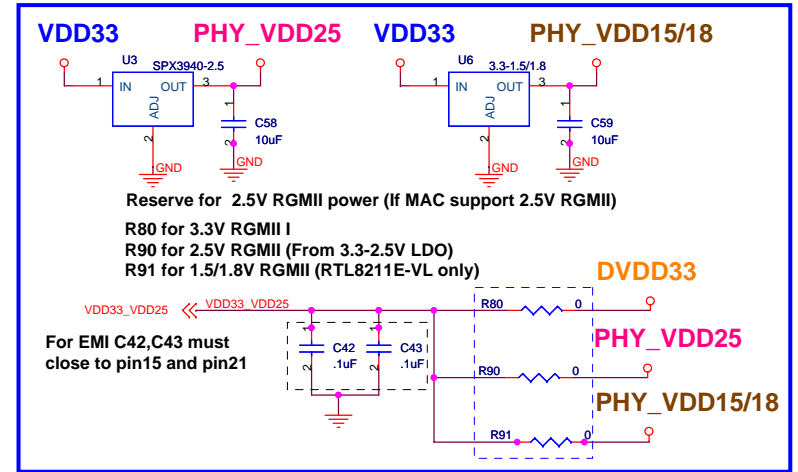

### 1.05V Power

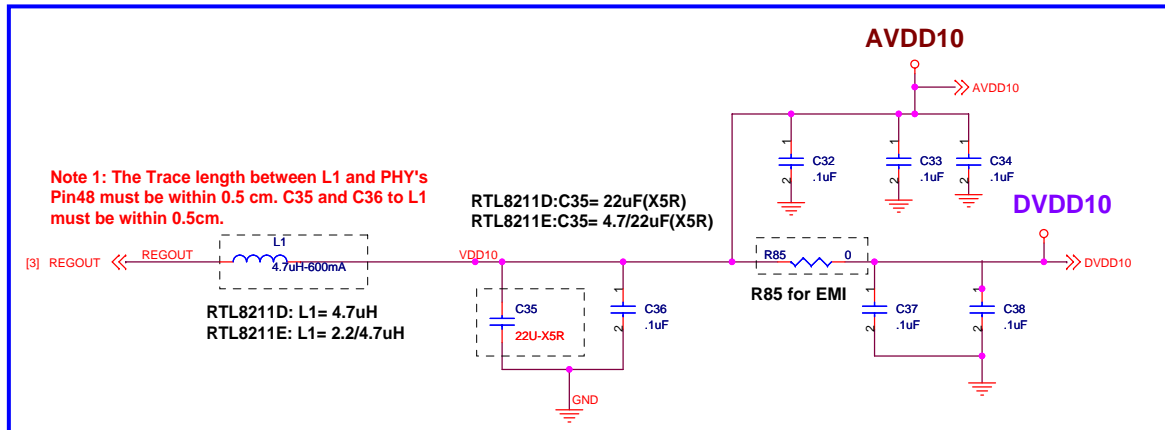

### External Power Source (1.05V)

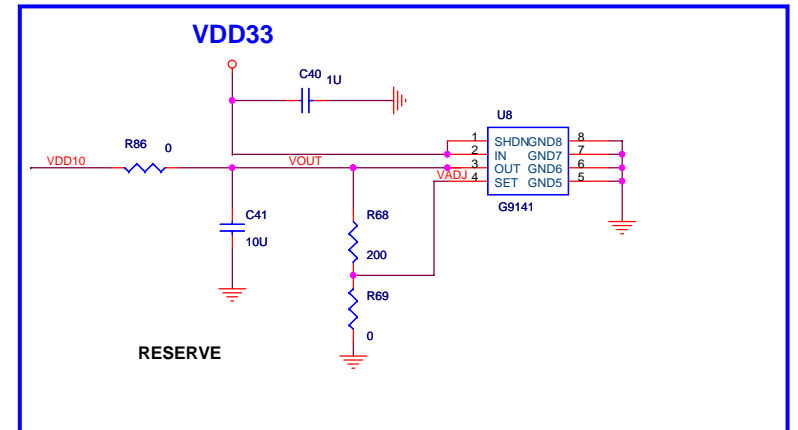

### VDDREG

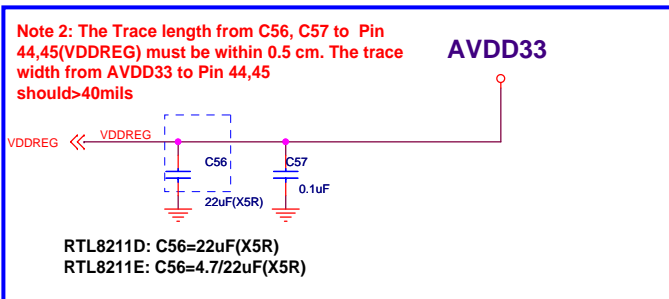

## History

Version	Date	
V1.0	2010.8.10	First release
V1.1	2010.12.3	Modify LED2 and MDIO pull up circuit
V1.2	2011.1.30	Remove ACR page
V1.3	2011.3.22	Add common mode choke for EMI Modify XTAL2 for RTL8211D
V1.4	2011.4.22	Modify transformer pin name
V1.5	2011.5.2	Add RTL8211E-VL 1.5V RGMII application
V1.6	2011.6.27	Add RTL8211E-VL 1.8V RGMII application

Title		
<b>RTL8211D/8211E</b>		
Size	Document Number	Rev
A3		
<b>HISTORY</b>		
Date:	Sheet	6 of 6