

# LAN9218 Reference Schematic

Schematic Revision 1.0

ITEM	Page
Title Page	1
LAN9218 Reference Schematic	2

Circuit diagrams utilizing SMSC products are included as a means of illustrating typical semiconductor applications; consequently complete information sufficient for construction purposes is not necessarily given. The information has been carefully checked and is believed to be entirely reliable. However, no responsibility is assumed for inaccuracies. Furthermore, such information does not convey to the purchaser of the semiconductor devices described any license under the patent rights of SMSC or others. SMSC reserves the right to make changes at any time in order to improve design and supply the best product possible.

			
Title <b>LAN9218 Reference Schematic</b>			
Size C	Engineer N/A	Assembly No. N/A	Rev 1.0
Date: Tuesday, July 10, 2007		Sheet 1 of 2	

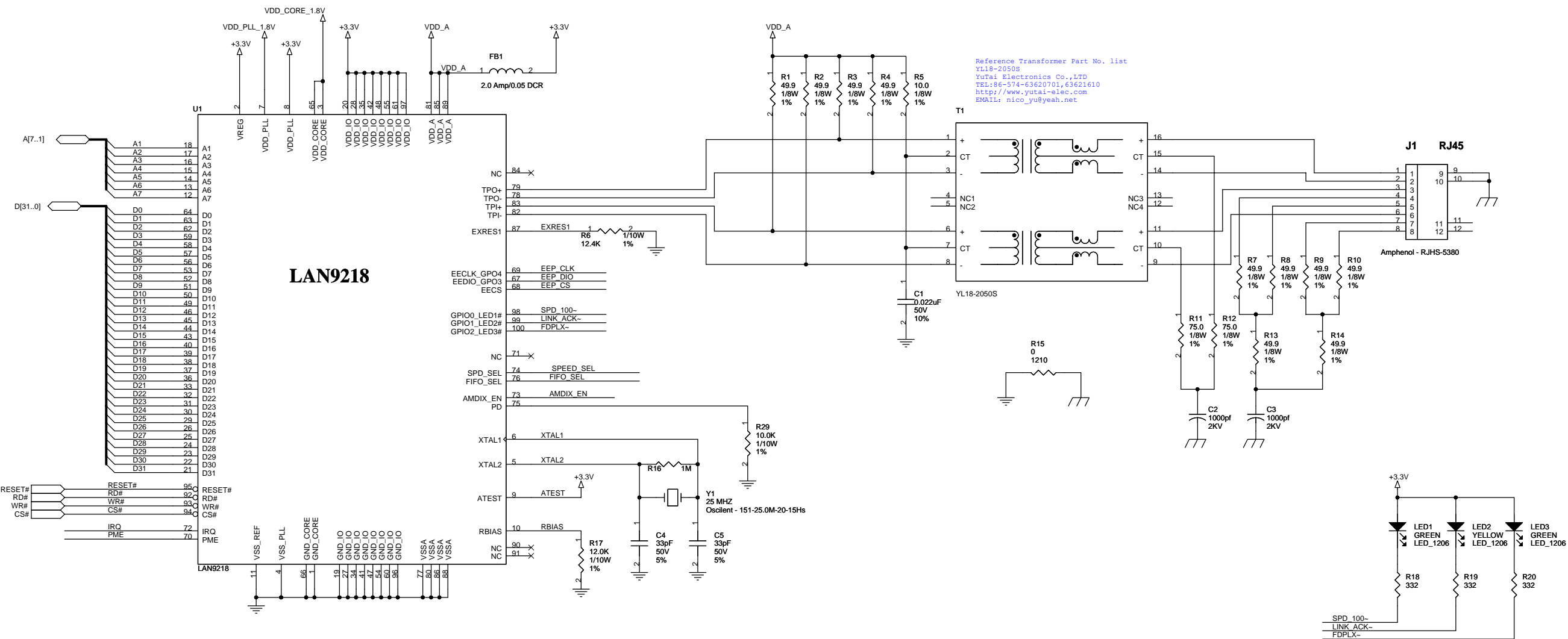

Reference Transformer Part No. list  
 YL18-2050s  
 YuTai Electronics Co.,LTD  
 TEL:86-574-63620701,63621610  
 http://www.yutai-elec.com  
 EMAIL: nico\_yu@yeah.net

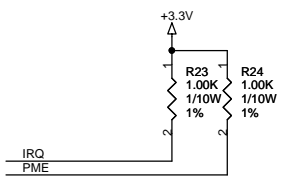
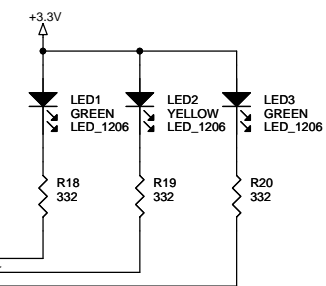

NOTE:  
 FIFO\_SEL can be driven dynamically and is not pulled internally to either state. This pin has the same timing as the Address Bus and can be driven by upper address bits not used by the LAN9218. Refer to datasheet.

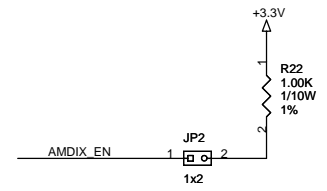

NOTE:  
 IN = Auto-MDIX Functionality Enabled  
 OUT = Auto-MDIX Functionality Disabled

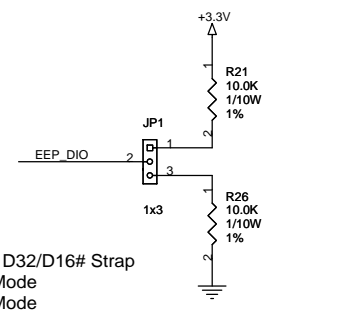

NOTE:  
 EE\_DIO is the D32/D16# Strap  
 1 - 2 = 32 Bit Mode  
 2 - 3 = 16 Bit Mode

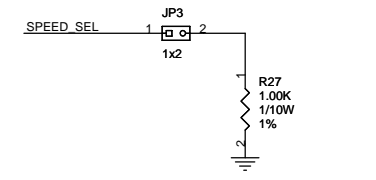

NOTE:  
 IN = 10Mbps, Half-Duplex, Auto Neg. Disabled  
 OUT = 100Mbps, Half-Duplex, Auto Neg. Enabled

### LAN9218 Decoupling Capacitors

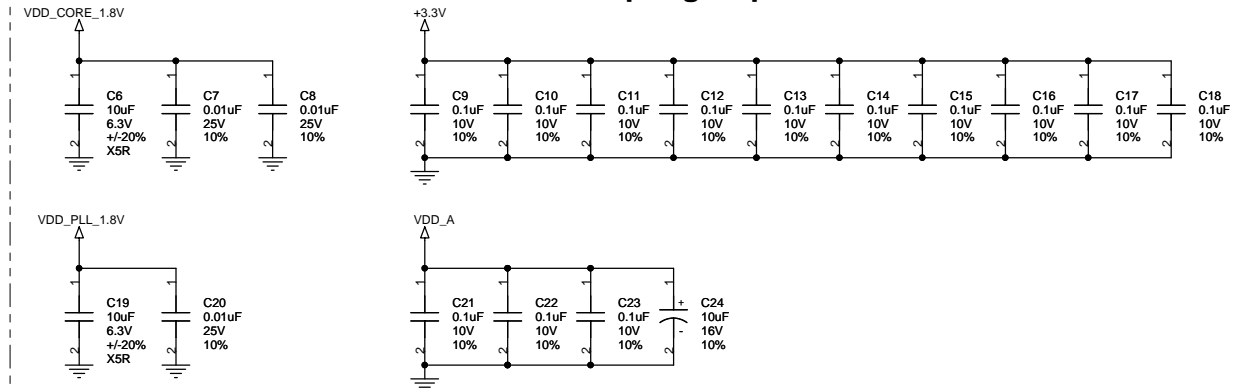

NOTE:  
 C6 and C19 must be low ESR capacitors. Ceramic is recommended.

### MAC EEPROM (Optional)

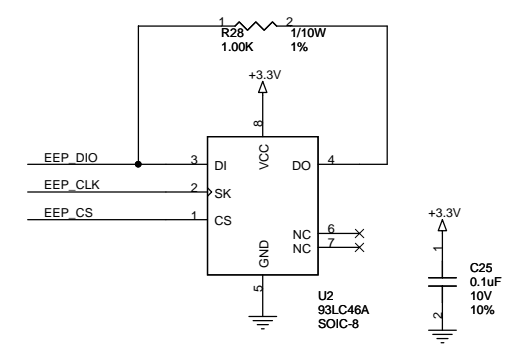

**LAN9218 Reference Schematic**

Size	Engineer	Assembly No.	Rev
C	N/A	N/A	1.0
Date:	Tuesday, July 10, 2007	Sheet	2 of 2